

BRISTAN

Artisan Thermostatic Lever Basin Mixer

Installation Instructions & User Guide

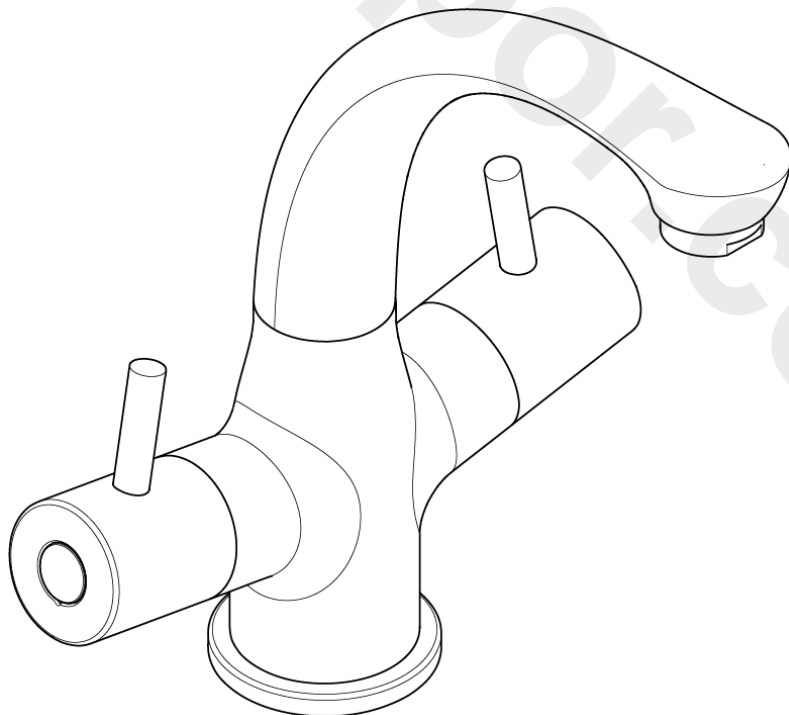

Please keep these instructions for future reference and request of replacement parts

Thank you for choosing Bristan, the UK's leading taps and showers expert. We have designed this product with your enjoyment in mind. To ensure that it works to its full potential, it needs to be fitted correctly. These fitting instructions have been created to give you all of the information you need and, if you need any further help, please do not hesitate to give us a call on 0844 701 6273.

Specifications

Inlet Connections: 15mm copper connecting pipes

Operating Pressure Range: Minimum. 0.2 bar, Maximum 5.0 bar.
Maximum Static Pressure: 10.0bar.

Factory set temperature: 38°C (Can be re-set / overridden to suit site conditions).

Supply Requirements:

Minimum cold water supply temperature: 5°C
Maximum cold water supply temperature: 25°C
Maximum hot water supply temperature: 80°C
(a maximum hot water supply of 60-65°C is recommended for ablutionary purposes).

Note: The inlet hot water temperature must be at least 10°C above the required blend temperature (e.g. outlet temperature 43°C: Minimum hot supply 53°C).

Nominally equal (balanced) inlet supply pressures are recommended for optimum performance. If pressures are unequal, then a pressure reducing valve should be used.

This products has been tested to the TMV2 Scheme which complies with BS 1111:1999 (HP) thermostatic mixing valve standards. It also satisfies the requirements of the Water Supply (water fittings) Regulations 1999 and current bylaws.

BS6700 recommends the temperature of stored water should never exceed 65°C. A stored water temperature of 60°C is considered sufficient to meet all normal requirements and will minimise the build up of lime scale in hard water areas.

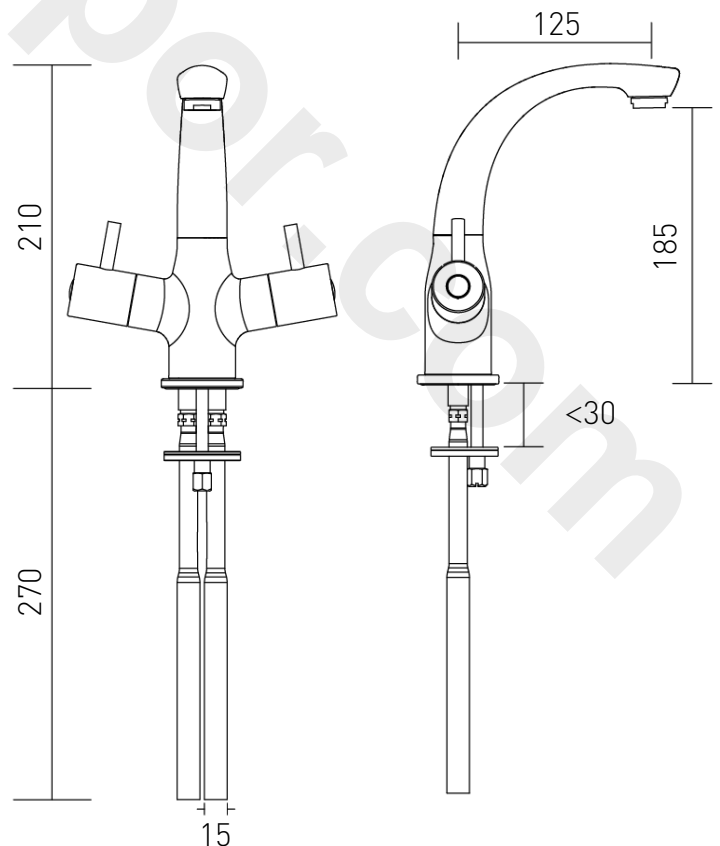

Installation Requirements

Conditions of use for Type 2 (Thermostatic mixer) valves

	High Pressure	Low Pressure
Maximum Static Pressure (Bar)	10	10
Flow Pressure, Hot & Cold (Bar)	0.5 to 5	0.1 to 1.0
Hot Supply Temperature (°C)	55 to 65	55 to 65
Cold Supply Temperature (°C)	Equal to or less than 25	Equal to or less than 25

Note: Valves operating outside these conditions cannot be guaranteed by the Scheme to operate as Type 2 valves.

The valves designation of use, LP if tested against BS EN 1287, HP if tested against BS EN 1111 and HP and LP if tested against both standards.

If a water supply is fed by gravity then the supply pressure should be verified to ensure the conditions of use are appropriate for the valve.

Recommended Outlet temperatures

The BuildCert TMV scheme recommends the following set maximum mixed water outlet temperatures for use in all premises:

41°C for Washbasins

The mixed water temperatures must never exceed 46°C.

The maximum mixed water temperature can be 2°C above the recommended maximum set outlet temperatures.

Note: 46°C is the maximum mixed water temperature from the bath tap. The maximum temperature takes account of the allowable temperature tolerances inherent in thermostatic mixing valves and temperature losses in metal baths.

 **Warning: It is not a safe bathing temperature for adults or children.**

The British Burns Association recommends 37 to 37.5°C as a comfortable bathing temperature for children. In premises covered by the Care Standards Act 2000, the maximum mixed water outlet temperature is 43°C.

The thermostatic mixing valve (TMV) will be installed in such a position that maintenance of the TMV and its valves and the commissioning and testing of the TMV can be undertaken.

The fitting of isolation valves is required as close as is practical to the water supply inlets of the thermostatic mixing valve.

Prior to Installation

Identify all components prior to stating installation.

This mixer tap should be installed in compliance with current water regulations. For further details contact your Local Water Authority.

The fitting of isolation valves is required as close as is practical to the water supply inlets of the thermostatic mixing valve.

The fitting of strainers is recommended as close as is practical to the water supply inlets of the thermostatic mixing valve.

This mixer tap is suitable for the following systems:

- Gravity Fed Hot & Cold (Equal Pressures)
- Unvented Systems
- Gas Combination Boiler
- Pumped System (Equal Pressures)

Note: On gravity systems the minimum distance from the underside of the water tank / cylinder to the mixer tap must be at least 2 metres.

Before connecting the mixer tap, thoroughly flush through the water supply pipes to remove any remaining swarf, debris. Failure to do so may result in damaging the product.

Important: The spout must be fully tightened prior to installation as it is not designed to move / swivel.

Installation – See illustration opposite

1. Place the mixer tap (1) onto the work surface / sink ensuring the plinth & washer (2) are fitted.

2. Screw the fixing nut (6) onto the threaded rod (5). Thread the fixing rod through the 'C' shaped rubber and metal washers (3&4) and screw the threaded fixing rod (5) into the bottom of the mixer tap to secure the tap in position.

1. Mixer Tap
2. Shroud & Base washer
3. 'C' shaped rubber washer
4. 'C' shaped metal washer
5. Metal fixing rod
6. Metal fixing nut
7. Copper connecting pipes

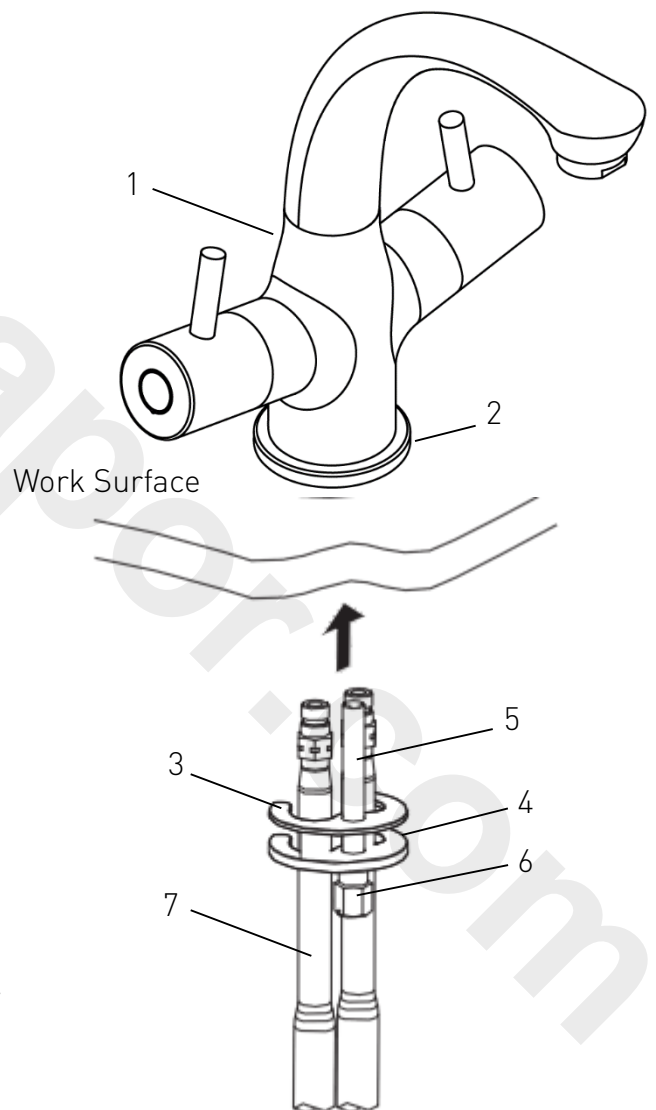

3. Screw the copper connecting pipes (7) into the mixer tap.

Important: Tighten the copper connection pipes fully by **hand only (DO NOT OVERTIGHTEN)**.

Connect the hot and cold water supplies to the mixer tap ensuring the hot on the left and cold on the right (when viewed from the front).

4. Turn on both water supplies letting the water run at both hot and cold settings for a few minutes to check all joints and connections for any leaks.

Important: Access must be made available to the copper connecting pipes and fixings for future maintenance / servicing.

Temperature Setting – See Illustration below

The temperature is factory set at 38°C, however this may be overridden by simply pressing the temperature override button in when the handle reaches the stop and continuing to turn the handle.

To reset the maximum temperature the following should be carried out.

1. Remove the end cap (1).
2. Unscrew the handle screw (2).
3. Remove the handle (3).
5. Turn the valve spindle (4) in the Required direction.

To increase the temperature turn the spindle anti-clockwise

To decrease the temperature turn the spindle clockwise.

5. Replace the handle (3), tighten the screw (2) and push fit the cap (1) back into position.

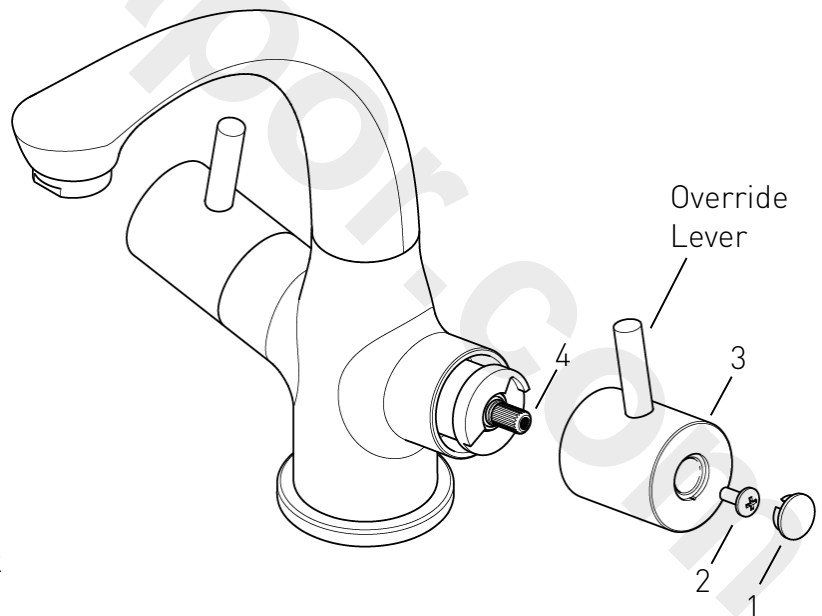

Commissioning

Commissioning notes for Thermostatic Mixing Valves

The first step in commissioning a thermostatic mixing valve is to check the following:

1. The designation of the thermostatic mixing valve matches the application.
2. The supply pressures are within the valves operating range.
3. The supply temperatures are within the valves operating range.
4. Isolating valves (and strainers preferred) are fitted.

If all these conditions are met, proceed to set the temperature as stipulated in the setting section.

The mixed water temperature at the terminal fitting must never exceed 46°C.

When commissioning / testing is due the following performance checks shall be carried out:

- Measure the mixed water temperature at the outlet.
- Carry out the cold water supply isolation test by isolating the cold water supply to the TMV, wait for five seconds, if the water is still flowing check that the temperature is below 46°C.

If there is no significant change to the set outlet temperature ($\pm 2^{\circ}\text{C}$ or less change from the original setting) and the fail –safe shut off is functioning, then the valve is working correctly and no further service work is required.

Notes: If there is a residual flow during the commissioning or the annual verification (cold water supply isolation test), then this is acceptable providing the temperature of the water seeping from the valve is no more than 2°C above the designated maximum mixed water outlet temperature setting of the valve.

Temperature readings should be taken at the normal flow rate after allowing for the system to stabilise.

The sensing part of the thermometer probe must be fully submerged in the water that is to be tested.

Any TMV that has been adjusted or serviced must be re-commissioned and re-tested in accordance with the instructions in the setting section.

The installation of thermostatic mixing valves must comply with the requirements of the Water Supply (Water Fittings) Regulations 1999.

General Cleaning

Your fitting has a high quality finish and should be treated with care to preserve the visible surfaces. All finishes will wear if not cleaned correctly. The only safe way to clean your product is to wipe with a soft damp cloth. Stains can be removed using washing up liquid. All bathroom cleaning products (powders and liquids) will damage the surface of your fitting, even the non-scratch cleaners.

Note: Never use abrasive detergents or disinfectants or those containing alcohol, hydrochloric or phosphoric acid.



Bristan recommend E-cloth for cleaning all of our bathroom & kitchen products. Using just water, E-cloth gives a smear free, deep clean by breaking up and holding dirt, which normal cloths leave behind. Order through your Bristan stockist (order code: ECLOTH).

Maintenance

We advise that your product is regularly serviced, particularly in hard water areas to reduce the build up of lime scale and to ensure your product performs to its full potential.

To service the mixing valve the following should be carried out.

Flow Valve servicing / replacement

Turn off both the hot and cold water supplies to the mixing valve and close any stop / service valves.

Remove the cap (1) and loosen the screw (2).

Pull the handle (3) off from the valve spindle.

Unscrew the valve (4) and clean / replace with a new valve supplied by Bristan.

Re-fit valve (4) and push the handle (3) onto the valve spindle.

Tighten the screw (2) and push-fit the cap (1) into position.

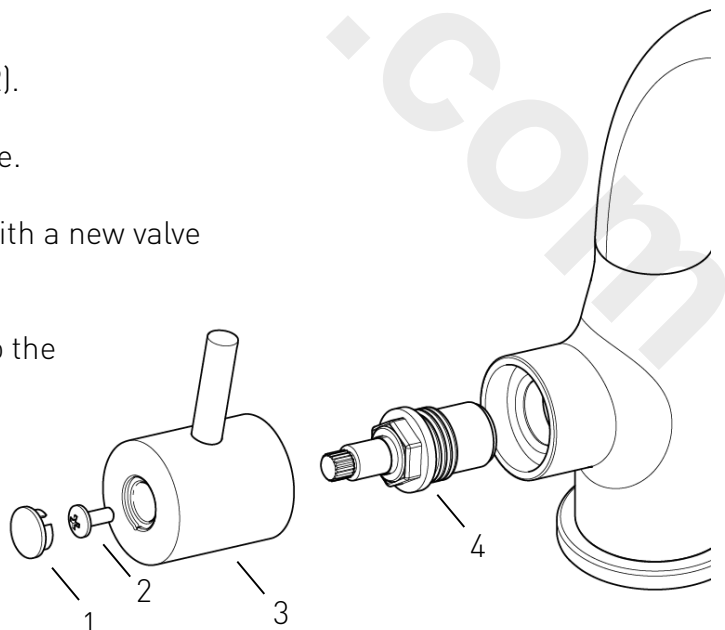

Flow Valve servicing / replacement

Turn off both the hot and cold water supplies to the mixing valve and close any stop / service valves.

Remove the cap (1) and loosen the screw (2).

Pull the handle (3) off from the valve spindle.

Remove the temperature stop (4), remembering the position when removed.

Unscrew the cartridge (5) and clean / replace with a new valve supplied by Bristan.

Re-fit cartridge (5), and temperature stop (4) in the same position when removed.

push the handle (3) onto the valve spindle.

Tighten the screw (2) and push-fit the cap (1) into position.

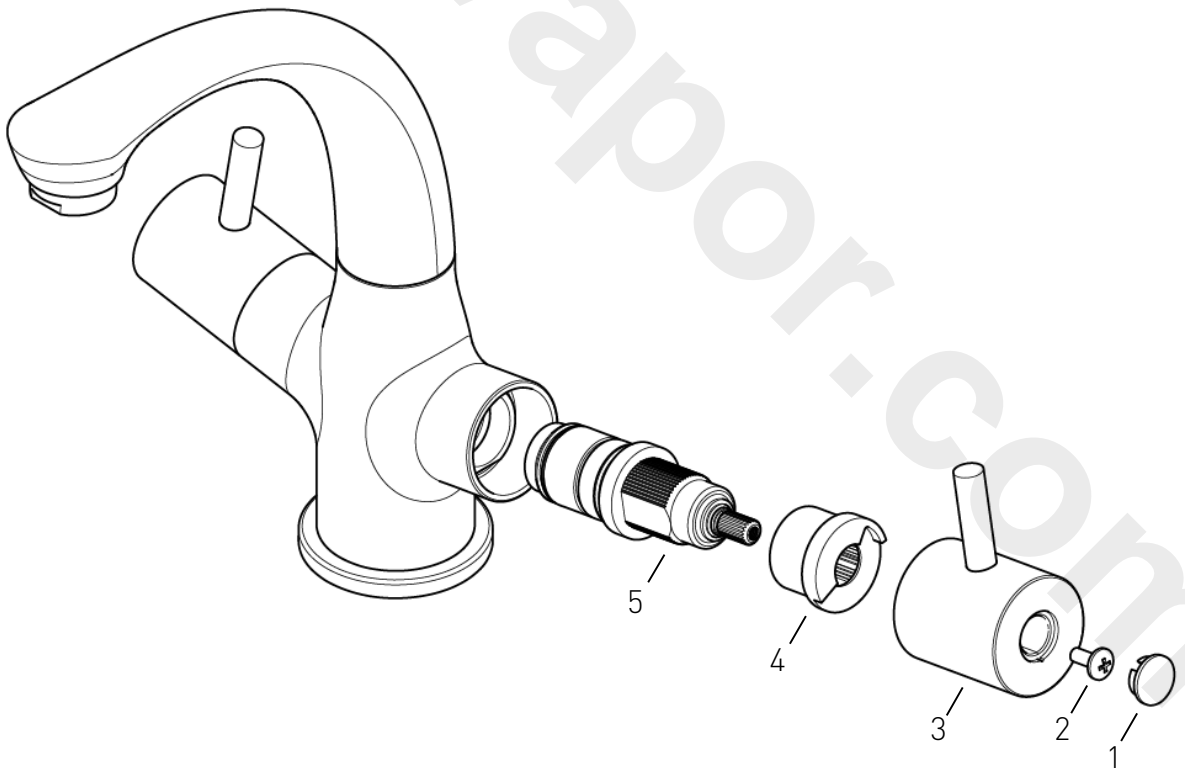

Troubleshooting

Symptom	Cause	Remedy
Maximum water temperature too hot or cold.	Maximum water temperature set incorrectly.	Reset maximum water temperature. Refer to 'Commissioning' section.
Outlet water temperature too hot / cold.	Inlet filter is partially blocked.	Check inlet filters for any blockages and clean as necessary.
	Installation conditions outside operating parameters.	Service shower valve as recommended. Refer to maintenance section.
Water temperature too cold – maximum water temperature incorrectly set.	Hot water temperature is less than 10°C above the required blend temperature.	Adjust hot water temperature or wait for water to reheat if stored system is used.
	Instantaneous water heater not igniting because water flow rate is too low.	Increase water flow rate through the system. Check cartridge inlet filters and clean or replace. Refer to maintenance section. Contact the boiler manufacturer.
	Instantaneous water heater not igniting because water pressure is too low.	Refer to 'Specification' for system requirements. Increase water pressure through system. Contact the boiler manufacturer.
Only hot or cold water from TMV outlet.	Inlet water supplies are reversed (hot to cold supply).	Check the connections are the correct way round. Hot on the left and cold on the right when viewed from the front. Rework pipework as necessary.
	Inlet filter is partially blocked.	Clean or replace, flush through pipework before refitting.

Troubleshooting

Symptom	Cause	Remedy
No flow or low flow rate and / or varying temperatures.	Partially closed stop or service valve in water supply pipework to the mixer valve.	Open stop or service valve.
	Instantaneous water heater cycles on and off as the flow rate or pressure is too low.	Increase water flow rate or pressure through system Contact the boiler manufacturer.
	Head of water is below the minimum distance required.	Refer to the specification section.
	Inlet filter is partially blocked.	Clean or replace, flush through pipework before refitting.
	Hot or cold water being drawn off elsewhere causing pressure changes or instantaneous boiler changes.	Do not use other water outlets when using the shower valve.
	Make sure the maintained inlet pressures are nominally balanced and sufficient.	If pressures are unbalanced then a pressure reducing valve should be used.
	Airlock or partial blockage of the pipework.	Flush through pipework to ensure removal of debris and any airlocks.
	No hot or cold water reaching the shower valve.	Check hot and cold feeds (the valve will shut down if either the hot or cold supply fails).

Bristan Guarantee

BRISTAN

Bristan offers solid guarantees to provide you with complete peace of mind.

Taps and Mixers

5 year parts and 1 year labour*. Gold, painted and special finishes 3 years parts only.

All subject to proof of purchase.

Mixer Shower Valves

5 year parts. 5 year labour* (subject to registration), or 1 year with proof of purchase.

Gold, painted and special finishes 3 years parts only.

Pumps and Power Showers

2 year parts. 1 year labour* (subject to registration).

Electric Showers/Instantaneous Water Heaters

2 year parts. 1 year labour* (subject to registration).

Accessories

5 year parts only. Includes bathrooms accessories, shower accessories (e.g. hoses, handsets and poles), wastes, WC levers and light pulls. Gold, painted and special finishes 3 years parts only.

Sanitaryware

5 year parts only. Subject to proof of purchase.

Shower Enclosures and Shower Trays

10 year parts (subject to registration), or 2 years with proof of purchase. 1 year labour* (subject to registration), or 1 year with proof of purchase.

Heated Towel Rails

5 year parts only. Gold, painted and special finishes 3 years parts only. All subject to proof of purchase.

*Labour provided by an approved Bristan engineer. Guarantee only applies to products with a manufacturing fault. A deferred payment will be necessary in order to secure any visits by our engineers which will be charged if the problem is found **not** to be a manufacturing fault. If the fault is found to be down to a manufacturing error, the payment will be released and not charged.

This guarantee applies to products purchased within the United Kingdom or Republic of Ireland, but does not apply to products used commercially.

The guarantee is only available to original purchasers who have proof of purchase.

The installation must allow ready access to all products for the purpose of inspection, maintenance or replacement.

Any part found to be defective during the above guarantee period will be replaced without charge, providing that the product has been installed in accordance with the instructions, used as intended, and regularly serviced.

Servicing should be carried out at regular intervals of no more than 12 months and more frequently in hard water areas (heavy lime scale) areas.

In the unlikely event that any problems are encountered with the product's performance on installation, you must obtain guidance/authorisation from our Customer Service Department, and be able to supply proof and date of purchase, before any remedial action is taken.

The guarantee excludes general wear and tear and damage caused by accident, misuse or neglect, and does not cover the following:

- Components that are subject to general wear and tear such as filters, seals, 'O' rings and washers etc.
- Damage caused by faulty installation
- Damage caused by lime scale or any waterborne debris
- Damage caused by inappropriate cleaning products (see user instructions)
- Damage caused by the use of non-Bristan parts
- The product being used for a purpose other than intended by the manufacturer.

In the interests of continuous product improvement Bristan reserves the right to alter specification as necessary.

If your product is out of its guarantee period, or you would like to extend the guarantee, then please see our [extended warranty offer](#).



Guarantee



Guarantee



Guarantee



Guarantee



Guarantee

BRISTAN

This booklet covers product codes
AR2 THLBAS C

Helpline

0844 701 6273

Bristan Group Limited

Birch Coppice Business Park, Dordon, Tamworth, Staffordshire B78 1SG

A Masco Company

Website: www.bristan.com

Telephone: 0844 7016 274 Facsimile: 0844 701 6275

Email: enquire@bristan.com